

# SL 609 OUTDOOR HLE

## TECHNICAL SPECIFICATIONS

Lifting cap. arm in/out	600/170kg - 1320/370lb
Lifting height	4150mm/163in
Extension of arm	700+900mm/ 28+35in
Tip from horizontal	40° back / 100° fwd
Side shift	100mm / 4in
Charging voltage	230 V / 110V
Charging time	Approx. 10 hrs.
Running period	Up to 10 hrs.
Front-wheel drive	1200 W AC
Suction pads	4 x Ø400mm / 4 x Ø16in
Width	830mm / 33in
Curb weight	940kg / 2070lb

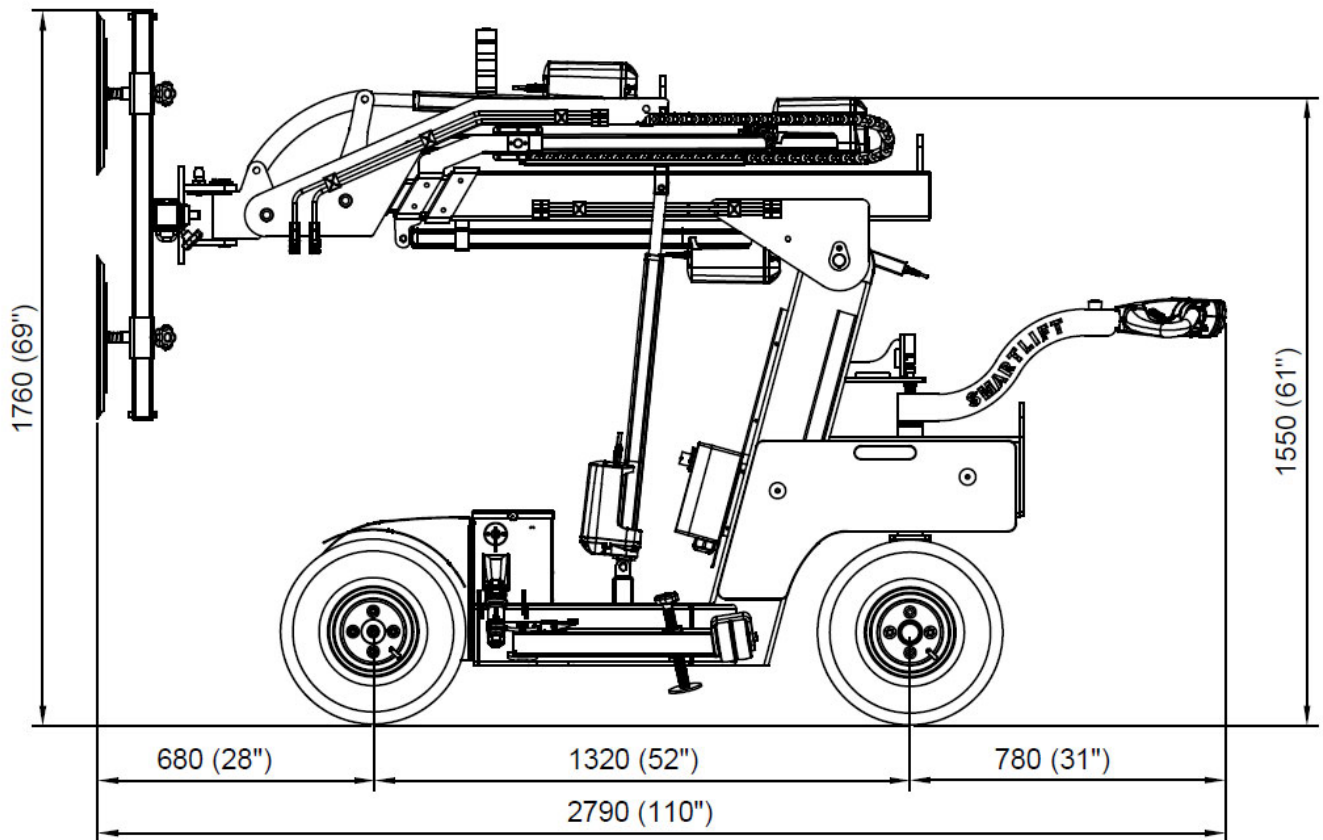
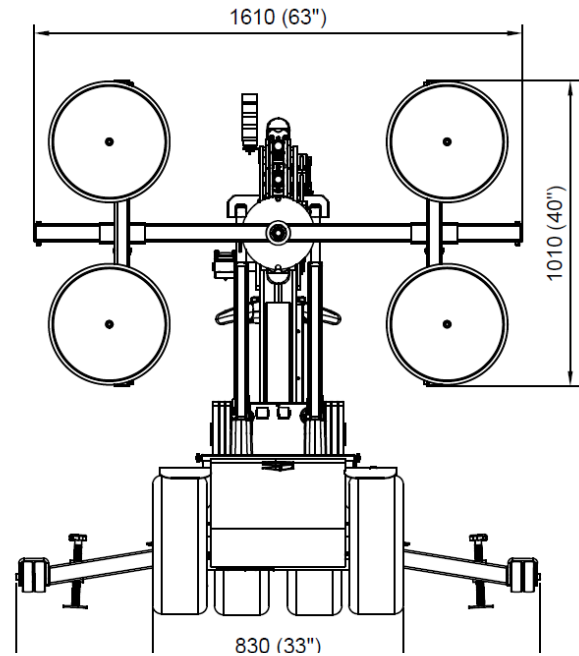

# SL 609 High Lifter Electric

180	250	320	390	460	530	600	kg
400	550	700	860	1010	1170	1320	lb

