



SMARTLIFT®

SL 280 INDOOR

TECHNICAL SPECIFICATIONS

Lifting cap. arm in/out	280/160 kg - 620/350 lbs.
Lifting height	2,700 mm / 106 in.
Extension of arm	500 mm / 20 in.
Tip from horizontal	50° back / 50° fwd.
Side shift	100 mm / 4 in
Charging voltage	230 V / 110V
Charging time	Approx. 8 hrs.
Battery (2 x 12V)	2 x 60 Ah
Running period	Up to 10 hrs.
Rear-wheel drive	700 W DC
Brake	Electro-magnetic
Suction pads	4 x Ø300mm / 4 x Ø12 in.
Width	620 mm / 25 in.
Curb weight	475 kg / 1,050 lbs.

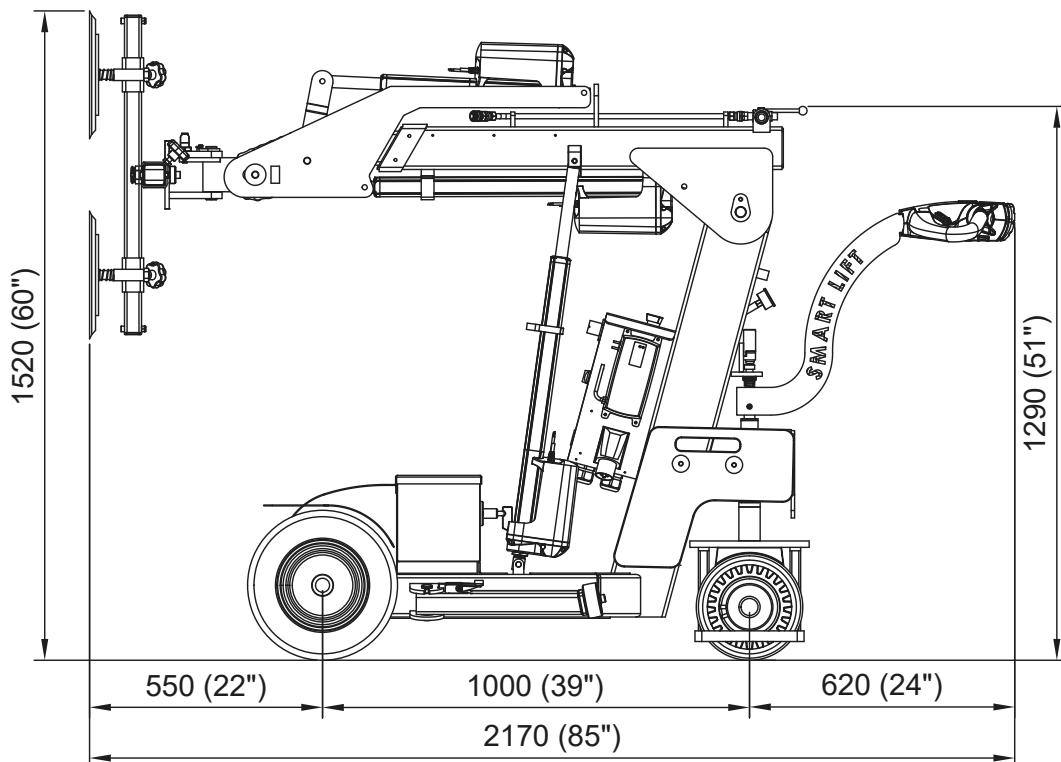
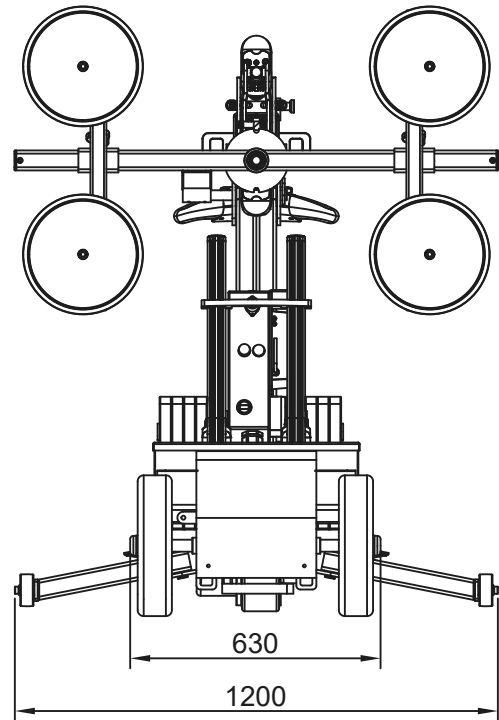

SL 280 INDOOR

