

# SL 1009 OUTDOOR

## TECHNICAL SPECIFICATIONS

Lifting cap. arm in/out	1000 / 280kg - 2200 / 620lb
Lifting height	4400mm / 173in
Extension of arm	2 x 830mm / 2 x 33in
Tip from horizontal	42° back / 86° fwd
Side shift	100mm / 4in
Charging voltage	230V / 110V
Charging time	Approx. 8 hrs
Battery	4 x 134 Ah AGM
Running period	Up to 9 hrs
Front-wheel drive	2500 W AC
Suction pads	6 x Ø400mm / Ø16in
Width	1010mm / 43in
Curb weight	1480kg / 3260lb
Class	IP 65

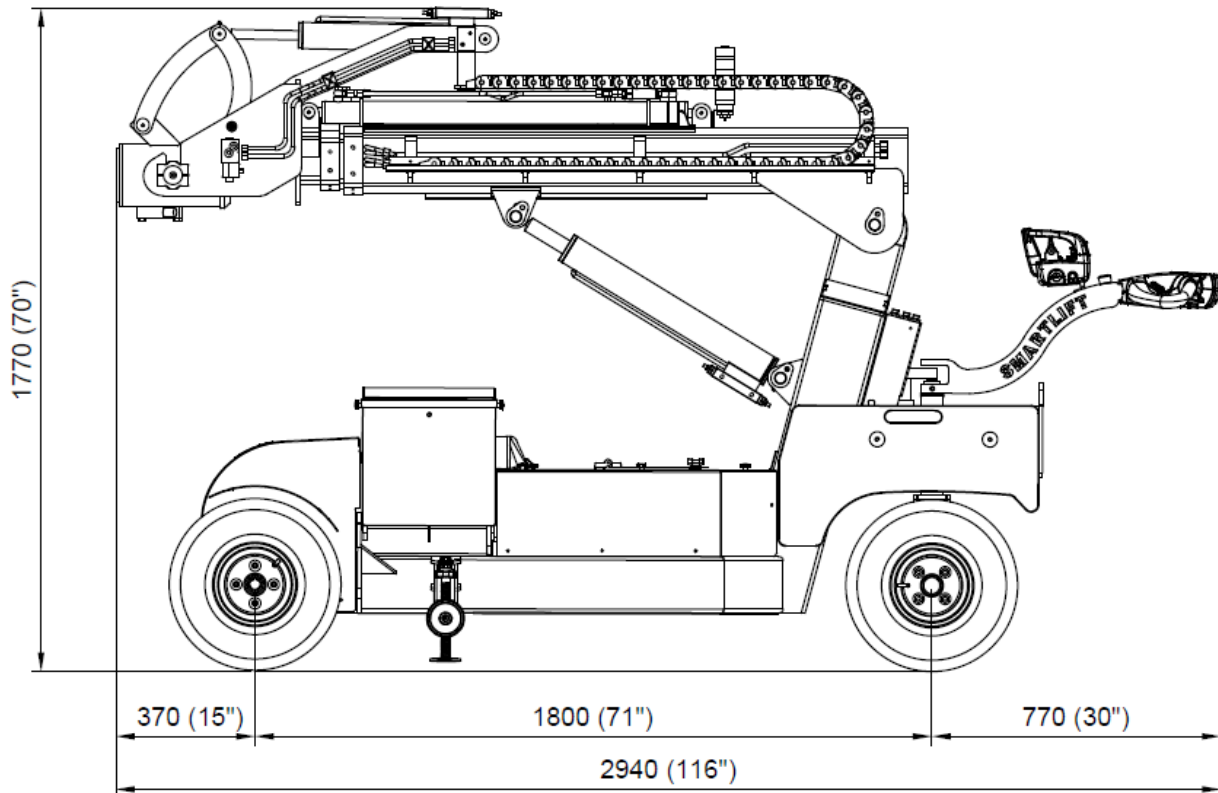
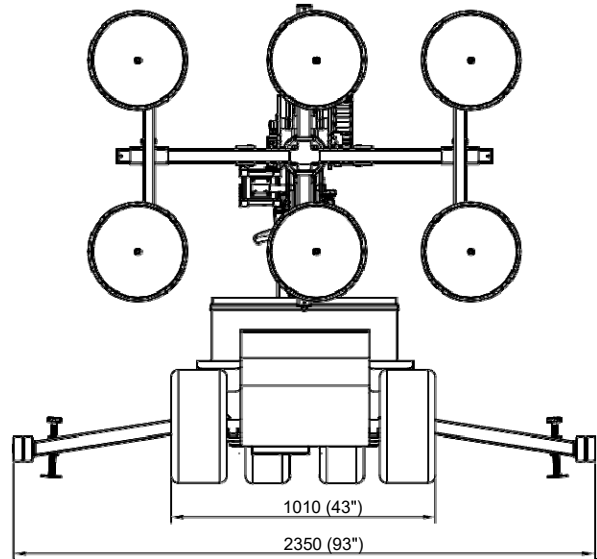

# SL1009 Outdoor

