

CTETRACCESS 230

- ↑ 23 m
- 12 m
- 👤 200 kg

Excellent performance.
Weight ratio.

Versatility.
Compactness.
Performances.



CTE TRACCESS 230

23 m of working height, an impressive outreach of 12 m with 200 kg of basket capacity.
< 3 ton weight easy for your transport solution.



Unrestricted working area



Winch with 230kg lifting capacity



The most versatile stabiliser configuration



Doorway access

TECHNICAL DATA

- » Articulated boom (two elements) + telescopic boom (main boom + 2 extension) + jib
- » Sigma boom movement enabled by connecting rods
- » 360° non continuous turret rotation on bearing turntable
- » Proportional electro-hydraulic controls in basket
- » Engine start and stop controls from basket
- » Basket base in composite material with aluminium guardrails (1300 x 700 x 1100)
- » 90° right + 90° left hydraulic basket rotation (option)
- » Basket load sensing device
- » Radio remote control
- » Dual drive speed
- » Narrow jacking facility
- » Extending width tracks
- » 110V 2.2 kW electric auxiliary motor
- » Automatic hydraulically actioned basket levelling
- » N° 4 hydraulic outriggers with ground pressure sensors
- » Hour meter
- » 110 V AC EC electrical socket in the basket
- » Standard boom colours blue (RAL 5017) or white (RAL 9003)
- » EN 280:2013 CE certified
- » Gradeability approximately 31%
- » Electro-hydraulic steering from the ground with radio control
- » Drive speed max 1.25 mph
- » 4 stabilization areas with hydraulic placement



watch the video

STRENX™
PERFORMANCE STEEL



- ## ENGINES
- » Honda 15 Hp petrol engine
 - » Kubota diesel engine
 - » 48V 300 Ah Lithium battery



DOORWAY ACCESS

PERSONALIZED STABILIZERS PADS



REMOTE CONTROL



ELECTRICAL VERSION

WORKING ENVELOPE

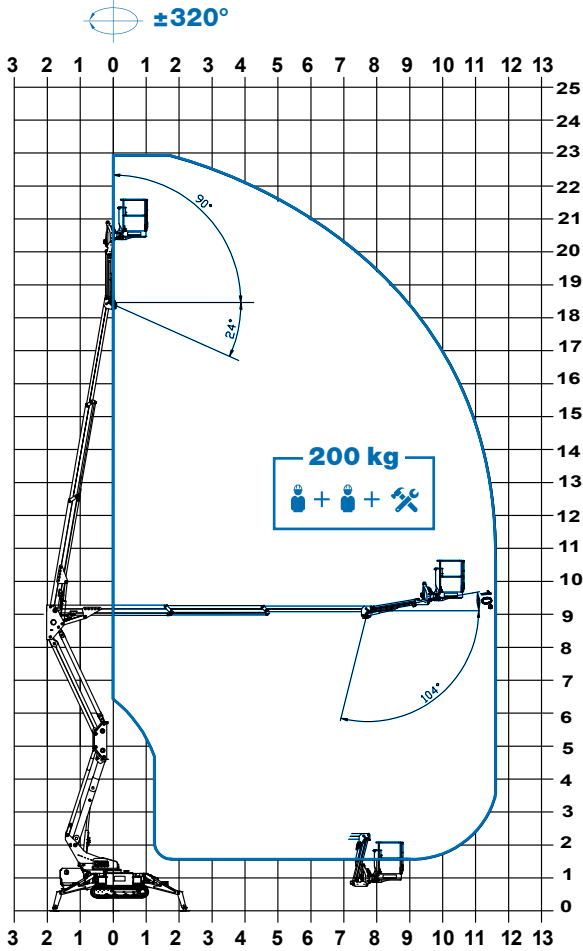

OUTRIGGER FOOTPRINT

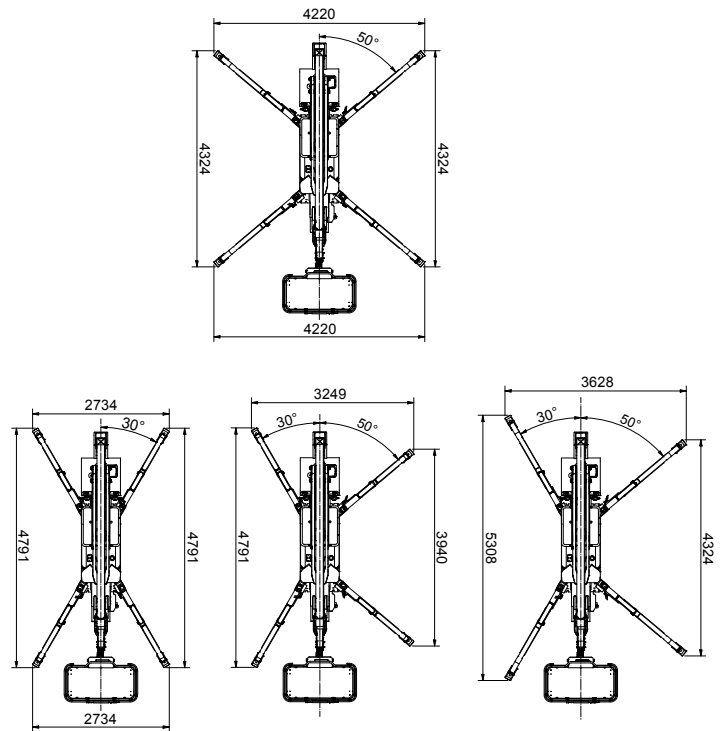

DIMENSIONS

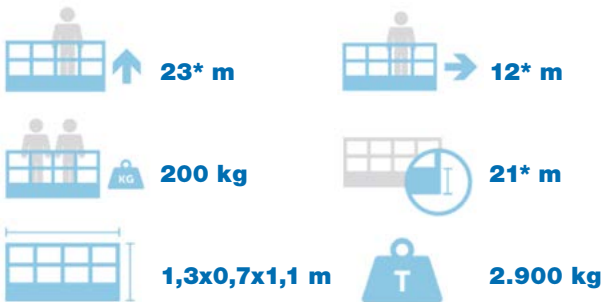
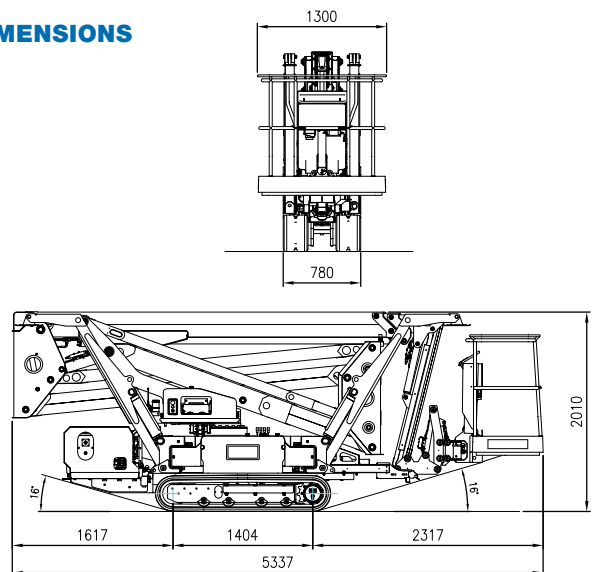

* outreach and height max values and repeatability can change within $\pm 3\%$ due to manufacturing variation and working condition.

Product specifications are subject to change without notice or obligation. Technical features and drawings in this brochure are for illustrative purposes only _TRACCESS 230 - ed. 08/22



Track-mounted range from 13 m to 27 m

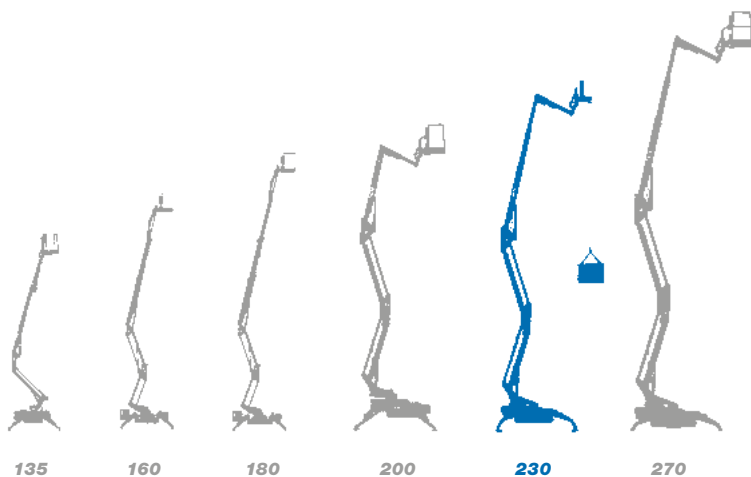

- ★ Most versatile boom configuration
- ★ Most compact machines in class
- ★ Clean top boom
- ★ Friendly to use intuitive controls
- ★ Easy maintenance
- ★ Excellent boom rigidity during operation
- ★ Versatility of engines and versions



We are CTE, one of the largest european groups in the field of lifting and handling of materials and people.



After sales assistance



Service spare parts



Scheduled maintenance



On-site assistance



Authorized workshops

Efficient services, innovative technical solutions, timely assistance, professional advice and training: 'Work Becomes Easy' is all this. A style, a philosophy at the heart of which are our customers, their safety, their quality of life. For this reason there is a group in CTE united by ideas, motivation and passion to simplify the work of companies active in the lifting of people and objects.



CTE s.p.a.
Via Caproni, 7
38068 Rovereto (TN)

Factory
Loc. Terramatta, 5
37010 Rivoli Veronese (VR)

Tel. +39 0464 48.50.50
info@ctelift.com
www.ctelift.com



UNI EN ISO 9001:2008 IT 61659