

SPECIFICATION

TRACCESS 170 E

100Ah LITHIUM BATTERY

WORKING ENVELOPE

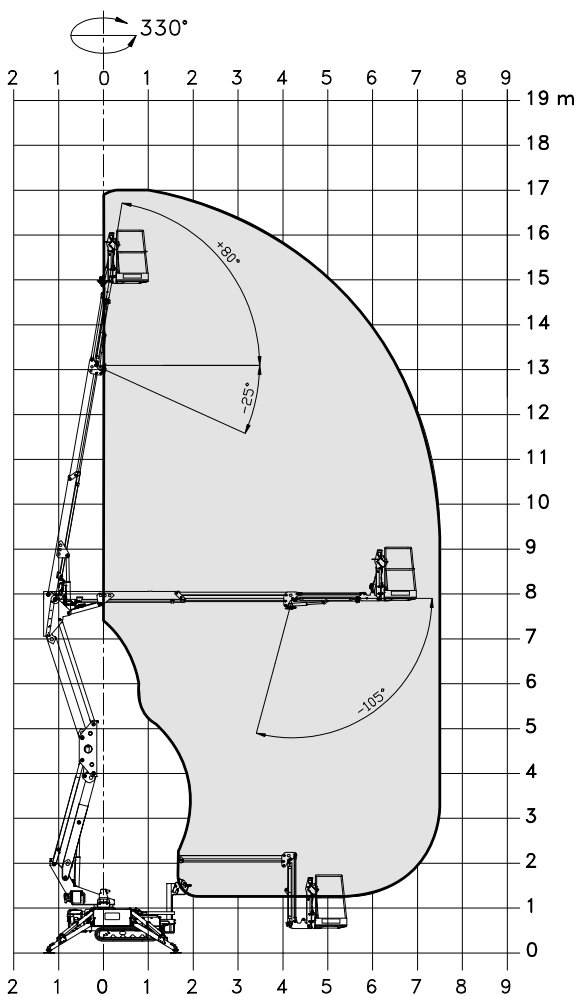

DIMENSIONS

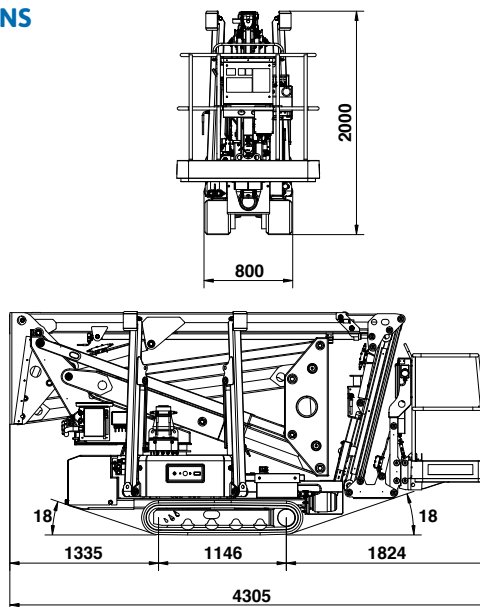

OUTRIGGER FOOTPRINT

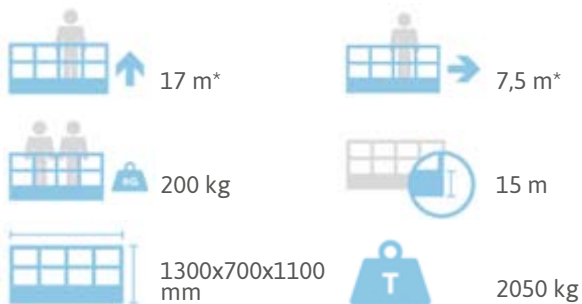
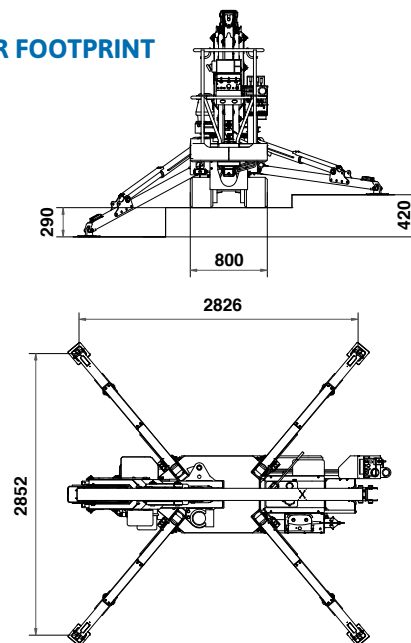

* outreach and height max values and repeatability can change within $\pm 3\%$ due to manufacturing variation and working condition.

Product specifications are subject to change without notice or obligation. Technical features and drawings in this brochure are for illustrative purposes only. TRACCESS 170 E - ed. 04/16



CTE S.p.A.
Headquarter and Factory
 7 Via Caproni - Rovereto (TN) IT, 38068
 Ph. +39 0464 48.50.50 - Fax +39 0464 48.50.99
 info@ctelift.com - www.ctelift.com
Factory 5 Loc. Terramatta - Rivoli Veronese (VR) IT, 37010
CTE UK Ltd Enderby Leicestershire - UK

